

Fulmatic 7—HMI Plus L0

Supply Voltage	24VDC (+/- %15)
Power Consumption	2.4W Standby
Program Cycle Time	Max loop speed 65 kHz
Digital Input / Output	16 Digital Input / 16 Digital Output
Analog Input / Output	6 Analog Input / 2 Analog Output
2x Serial Port	It is selected according to the model. RS485 / RS232
1x Ethernet	10/100Mbps Full Duplex, DHCP support, TCP ModBus support 5 simultaneous connections Web Server 512KB File space 10 simultaneous connections
I/O Capacity	512 Analog Input / 512 Analog Output or 8192 Digital Input / 8192 Digital Output
RTC	Real time clock (It works 30 days without electricity.)
Working Conditions	-20 +60 °C / 5-95% Humidity

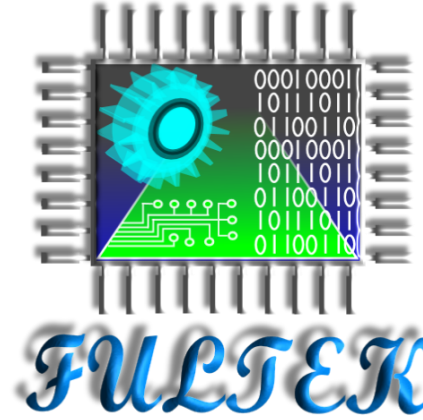

Fultek Kontrol Sistemleri San. ve Tic. Ltd. Sti.

Address: Buyuksehir Mah. Cumhuriyet
Cad. Ekinoks E2 Blok K:2 D:8
Beylikduzu / Istanbul

Phone:

+90 212 871 01 28

Email:

info@fultek.com.tr

Web site:

www.fultek.com.tr

Focus HMI Integrated Fulmatic 7 PLC Module

HMI Plus L0 (xP-xxxxxx-0x)

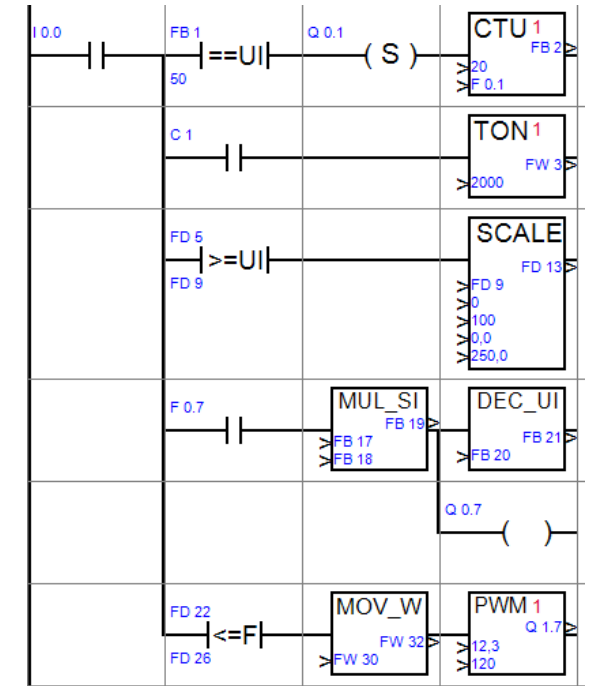

Fulmatic 7 - HMI Plus L0 Module

A. GENERAL FEATURES

Focus HMI Integrated Fullmatic 7 PLCs is a domestic production programmable controller that meets the demands of the industry, designed in accordance with the automation needs and designed considering the difficult conditions of the industry.

HMI Plus L0 (xP-xxxxxx-0x) module has 115 KB Program memory, 1x 10/100 MBit Full Duplex Ethernet, Modbus RTU and TCP, Web Server with 512 KB File space, 8x 200 kHz and 8x 50 kHz Digital Inputs, 8x 655 kHz 0.1A and 8x 20 kHz 0.5 A Digital Outputs, 1x 0-10 V and 1x 0-20 mA 12 bit Analog Outputs, 2x 12 bit Analog Inputs selectable as 0-10 V or 0-20 mA and there are 4x 16 bit Analog Inputs selectable as 0-10V, 0-20mA, PT100, PT1000, Resistor, Millivolt, ADC, Thermocouple (Type B, E, J, K, N, R, S, T).

B. TERMINAL CONNECTIONS

Supply and Communication Connections

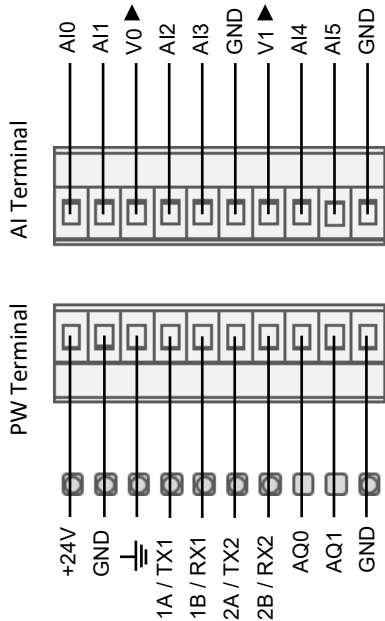

!
Supply Voltage
24VDC

!
AQ0 Output 0-10V
AQ1 Output 0-20 mA

Digital Input and Digital Output Connections

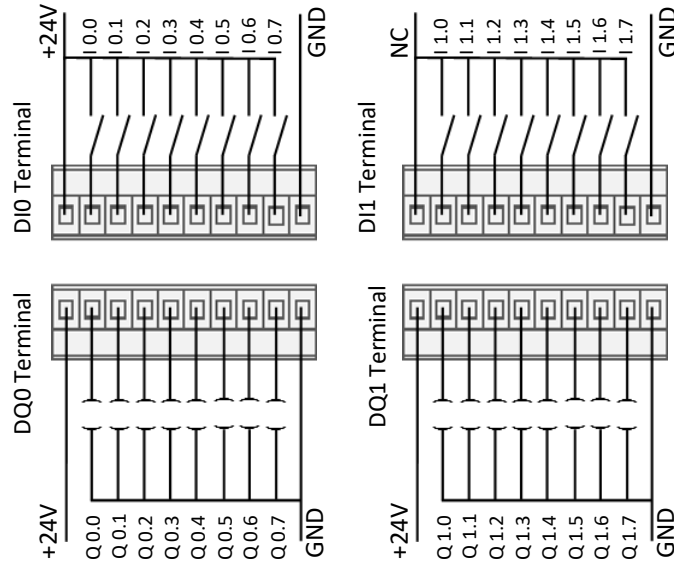

Analog Connections

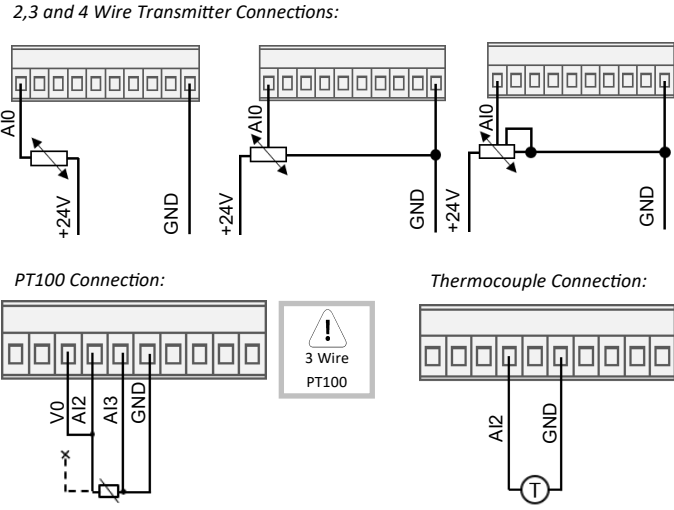

C. PRACTICAL INFORMATION

- **System Fault LED is on:** When the CPU has been without electricity for more than 30 days, the PLC clock needs to be updated. Connect to PLC with Speed PLC program and update PLC clock.
- **Stop LED is flash:** You will see this warning when the supply voltage drops below the tolerance voltage. Check the supply voltage.
- **COM TX/RX LED is not lit:** Check the RS485 A and RS485 B connections. Check whether the line termination resistor (120Ω) is installed at the end of the line. When it is RS232, there are 3 wires. Check that RX, TX and GND are connected correctly.
- **Can not connection to the CPU with Speed PLC:** Check the PLC connection settings in the Speed PLC program. If your connection port is Ethernet; Check the IP address, access port, PLC address. If you are connecting PLC via direct connection without network, you do not need a cross cable for connection. You should follow the instructions in the user manual on our website for the settings that required to be made for a direct connection. If your connection port is Serial port, check the serial port, baudrate, parity, PLC address and stop bit values.

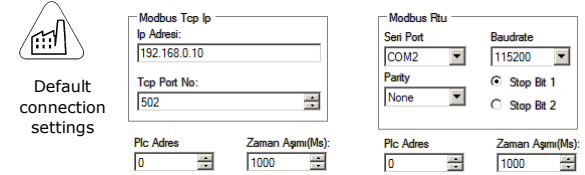

D. WARNINGS

- !** PLC must be de-energized before wiring. Wiring must be done in accordance with the connection diagram.
- !** Sections of the cables that connect to terminals should be taken into consideration. The cables to be connected must be used by stripping them to the point where they can enter into the terminal. It should be noted that excessively stripped cables may come into contact with cables in other terminals.
- !** When the power is on, removing and installing the cables in the terminal, adding and removing the expansion modules can cause damage to the PLC.

E. FACTORY SETTINGS

To return the integrated PLC module to factory settings, Off the power of integrated PLC module. Supply the integrated PLC module while pressing and holding the PLC Run/Stop button. Release the button when the Run LED is turned on, the PLC will return to the factory settings.